

PLAN VIEW

NOTES:

BOX FABRICATED FROM
10 GA. MATERIAL

L2½x2½x⅜
FRAME

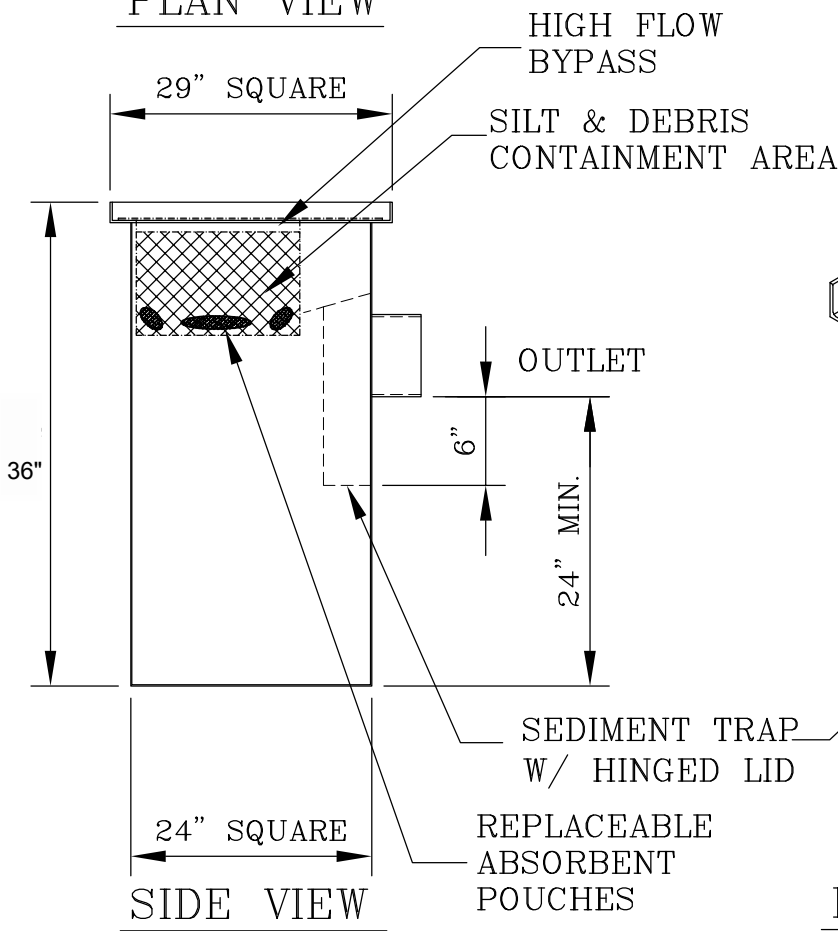

SIDE VIEW

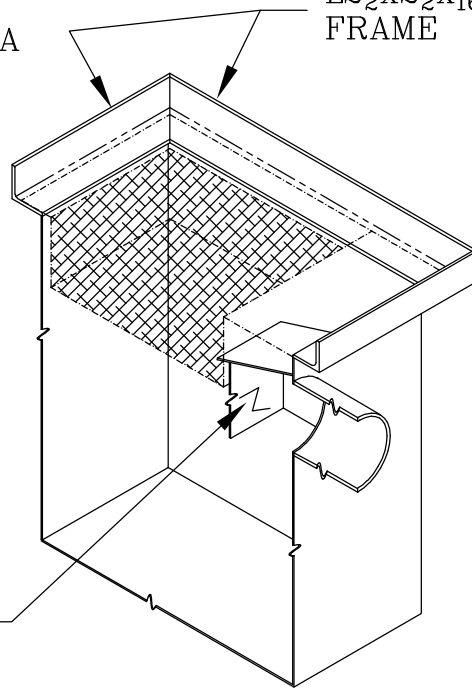

ISOMETRIC SECTION

SEDIMENT & HYDROCARBONS FILTRATION SYSTEM
STATE APPROVED - ASPHALT DIPPED

24" SQUARE - 4"Ø OR 6"Ø OUTLET

STORM WATER CATCH BASIN

MODEL: GCBF10-36HB-4&6

DATE: 11/19/2020

SCALE: NONE

DWG #
SF2

Gibson Steel Basins, Inc.

1040 Arrowsmith St. Eugene Or. 97402
(541) 484-7200 or (800) 574-8096

Visit us at: www.gibsonsteelbasins.com

Email us at: sales@gibsonsteelbasins.com

EST. 1996

CCB 150089