

PLAN VIEW

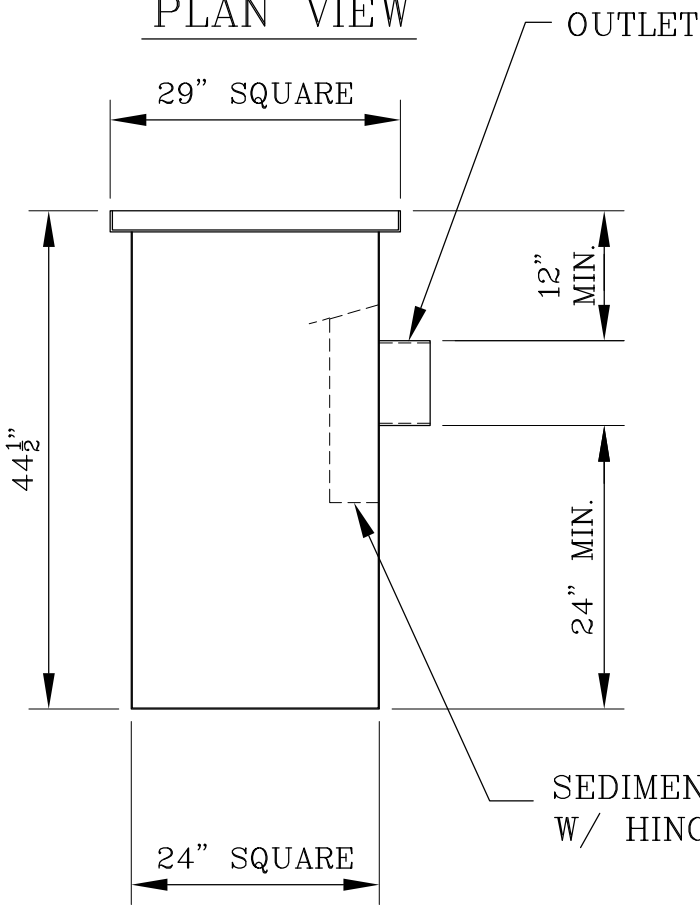

SIDE VIEW

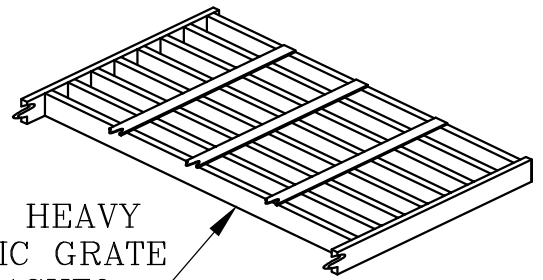

BIKE PROOF, HEAVY  
DUTY TRAFFIC GRATE  
SUPPORTS AASHTO  
H25 LOADS

GRATING

NOTES:

BOX FABRICATED FROM  
10 GA. MATERIAL

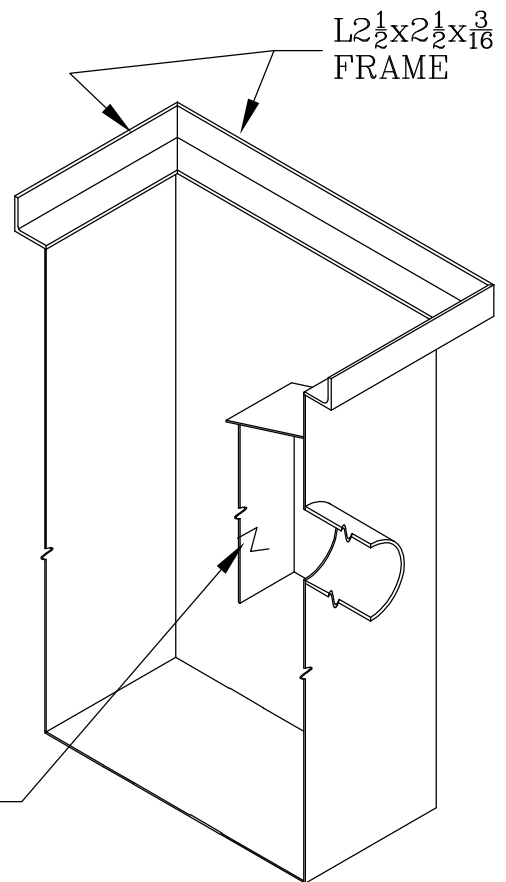

ISOMETRIC SECTION

STATE APPROVED — ASPHALT DIPPED



Gibson Steel Basins  
SINCE 1972

24" SQUARE — 4"Ø OR 6"Ø OR 8"Ø OUTLET

STORM WATER CATCH BASIN

PROJ. MAN. DOUG P.

DWN. PAUL G.

SCALE NONE

DATE: JAN. 23, 06

MODEL: MPCB10-42HB-4&6&8

DWG #

**T1**